



technical specifications LR7/90

general

- RBN401 pro-ribbon HF driver with exceptional intelligibility and “throw”
- All Neodymium drivers for excellent performance-to-weight ratio
- SIS pre-wired for very high damping and further reduced distortion (with ALC)
- Maximum attainable “gain-before-feedback”
- Durotect™ scratch-resistant coating
- Extended headroom/SPL and protection in combination with SDP circuit (in ALC)
- Passive filtering for easy operation and economical powering

description

The LR7 is a passive 2-way line-source loudspeaker system. It is a true line-array system, to be used as vertical array, either in stacked or flown configuration, for both portable and permanent installations. Loaded with the RBN401 pro-ribbon driver on a “Morpher” lens (up to 94% frontal radiation!), the system features 90° dispersion with seamless coverage, due to the ribbon’s all-natural cylindrical (Isophasic) wavefront. Its transient response and unusual high peak power handling (800W/200mS) caters for a superb intelligibility and throw, while offering maximum “gain-before-feedback” up to directly under the array.



The micro-sized design, combined with the weight-saving all Neodymium drivers, makes the system very easy to handle.

The “Morpher” is mounted in the “ALrad™” waveguide, which utilizes the stiffness and heat transfer capabilities of aluminium. Mounted on the RBN, the ALrad™ extends the cooling surface for even further reducing power-compression for increased SPL over time.

The SignalIntegritySensing™ pre-wiring ensures complete cable/connector compensation between the LR7 and ALC. Typical (short to medium throw) applications for the LR7 include as compact main system for theatre, A/V or corporate events where minimal sightline obstruction is required, with exceptional sound reproduction. It is available in 90° and 120° configuration.

In applications where extended bass response is required, the LR7 can be combined with a pressure-bass or deep-sub system.

For full system performance, we recommend using the LR7 in combination with an ALC amplifier/controller. Driven by the ALC, the LR7 delivers maximum sound quality with inaudible (power and excursion) protection (SDP circuit). All LR7 system presets are included in the library of the Digital Drive Processor™; with which also array-length and positioning (stacked/flown) can be adjusted.

More system application information can be found on www.theribbonnetwork.net

dimensional drawing

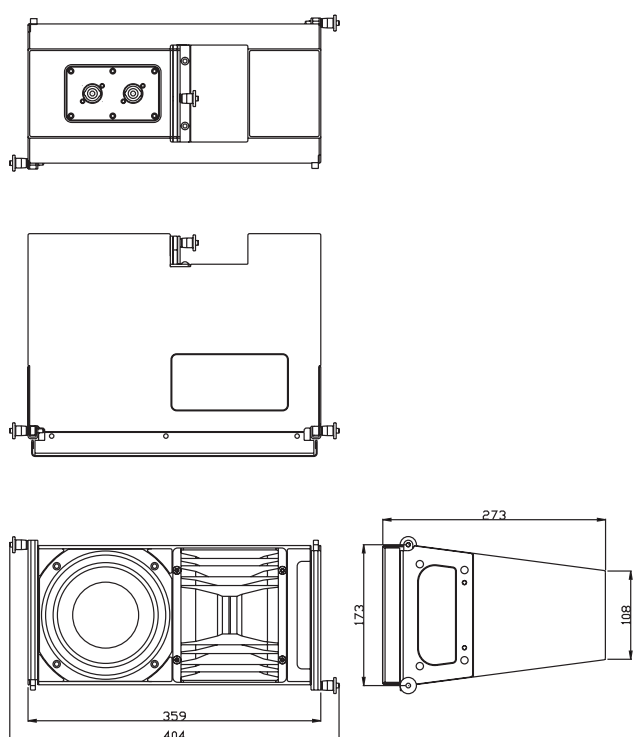

technical specifications

Frequency Response	
+/- 3 dB	74 Hz - 20.000 Hz
+/- 10 dB	53 Hz -
Sensitivity (SPL 1W/M)	92 dB
Sensitivity (nominal)	96 dB (200Hz. - 10kHz.)
Nominal Impedance	16 ohms
Maximum RMS power	200 W
Maximum peak power	800 W
SPL program/peak (nom.)	119/125 dB
Dispersion H x V (array)	90° x depending on array length
Dispersion H x V (single)	90° x 15°

physical specifications

System	2-way, full-range	
Filtering	passive	
Drivers LF	1 x AND6.5/16 6.5", vented	
Driver HF	1 x RBN401 4" pro ribbon driver	
Cross-over frequency	1000 Hz.	
Connectors	2 x Speakon NL4 input / link	
Physical dimensions	mm	inches
Height	173/108	6,9/4,3
Width	359	14,1
Depth	273	10,7
Weight (approx.)	8 kg	(17,6 lb)
Warranty	6 years limited	

A: Alcons Audio B.V.
De Corantijn 69
1689 AN Zwaag
The Netherlands

E: info@alconsaudio.com
W: www.alconsaudio.com
T: +31 (0)229 28 30 90
F: +31 (0)229 28 30 99